

MR100 SWR Analyzer

User Manual

Revision 3.0

This product is revised by SARK100, and the technology is from Melchor Varela(EA4FRB)

1 Specifications

- Frequency Generation & Control:
 - 1 - 60 Mhz
 - Source impedance: 50 Ohms
 - Stability: +/- 100 ppm
 - Spectral Purity: Harmonics down >- TBD dB beyond 60 MHz
 - Step Size: User configurable increments of 100 Hz, 1 kHz, 10 kHz, and 100 kHz

- Usable Measurement Range:
 - SWR: 1.0 to 9.99
 - Impedance: approx. 5 to 2000 ohms

- RF Output:
 - Adjustable: 2.0 Volts pp (typ)

- Power supply:
 - External: 13.8 to 19 Volts DC, 500mA
 - Internal: 8xAAA 1000mAh NiMH cells
 - Charging time: 12 hours (charge rate 0.1C)

- Controls:
 - Pushbuttons (5): "Mode", "Band", "Config", "Scan", "Up", "Down"
 - Switch: "Power On"

- Connectors:
 - RF Out: BNC
 - USB: Mini-B receptacle
 - External power: 2.1mm Power Jack (center pin positive)

- Instrument Capabilities:
 - Measure antenna electrical parameters: SWR, impedance (resistance + reactance), capacitance, inductance
 - Measure feedpoint impedance
 - Measure ground loss

- Adjust antenna tuners and determine loss
- Measure inductors and capacitors
- Measure coax transmission line (SWR, length, velocity factor, approximate Q and loss, resonant frequency, and impedance)
- Measure and determine optimum settings for tuning stubs: SWR, approximate Q, resonant frequency, bandwidth, impedance
- Determine characteristic impedance of transmission line
- Determine length of $\frac{1}{4}$ and $\frac{1}{2}$ wave phasing lines
- Coaxial Cable Loss
- Determine antenna tuner loss
- Measure balun loss
- Measure inductor Q
- Estimate quartz crystal parameters

2 Connections and Controls

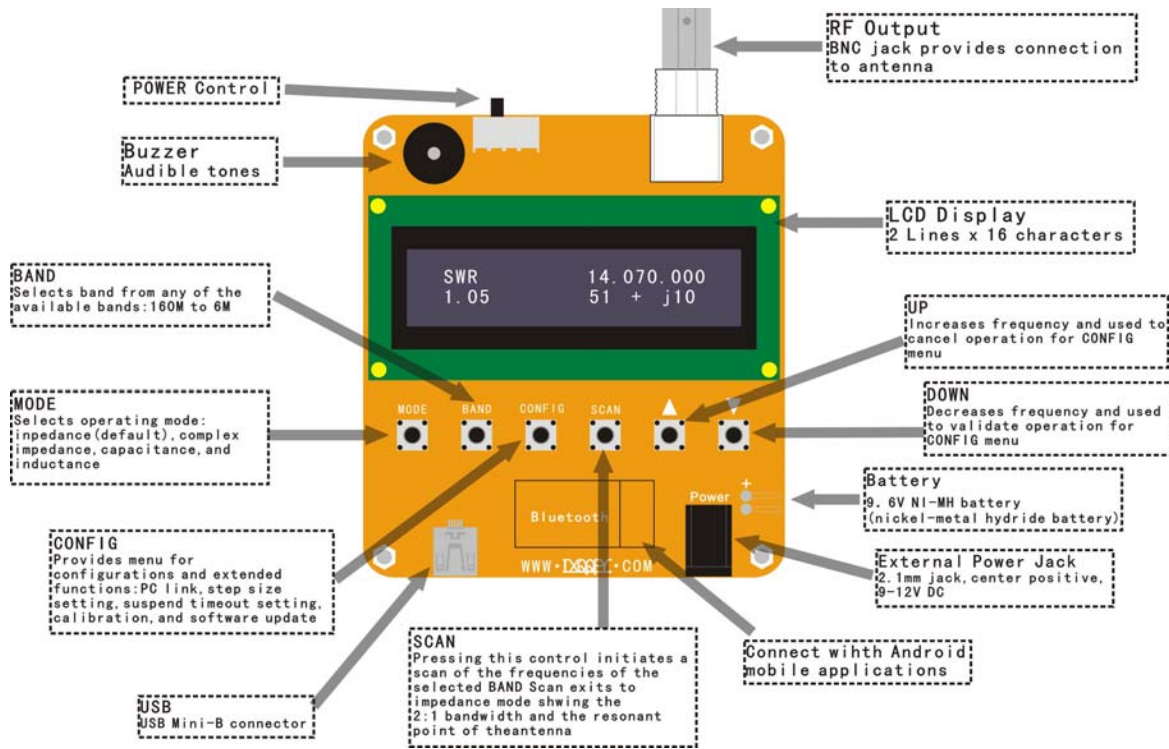

3 Connections and Controls

Power-on

Power is turned on to the MR100 by sliding the switch located on the bottom panel. After power-on the unit will display for half a second the following welcome message:

```
SARK100 Analyzer
(c) EA4FRB 10 V11
```

V11 indicates the unit firmware version. This information is important to check on the website of the project if there is a newer version. Then the instrument automatically switches to impedance mode that is the default mode and LCD shows frequency, SWR, and the magnitude of the impedance:

```
SWR 14,10.000
>10 Z=2000
```

The analyzer has an automatic power-save function. This function detects that no button was pressed after a user programmable time and goes into a power saving state and which turns off the display. In this state the press of any button will start immediately the unit returning to the same state before the suspension, i.e. the same function and frequency selected. This function can be disabled by the user.

It is important to note that this is an energy saving feature but not a full power-off, i.e. the instrument continues to have a significant consumption so it is recommended shutting down completely in the case it s not going to be used.

User Interface

The user interface consists of six buttons, four aimed at selecting the functions available and two are used primarily to select the frequency but have the dual function of canceling and validate respectively. All functions are summarized in the Appendix E:

Adjusting the Frequency

Frequency is changed by adjusting a single digit indicated at the point in the display where the cursor '_' is by pressing either frequency change button. Upon power-up of the instrument, the 10 kHz digit is the adjustment point, as shown by the digit with the cursor in the display below.

```
SWR 14,10.000
1.02 Z = 40Ω
```

To move the cursor to a different digit to be adjusted, press simultaneously the frequency change buttons. The cursor will move to any of the seven available digits, allowing subsequent up/down adjustment of that digit after pressing again the frequency change buttons. A blinking cursor will be display during the digit adjustment mode.

SWR 14,1•0.000

1.02 Z = 40Ω

Pressing the left button will increase the digit value and, correspondingly, the signal generated by the unit. Pressing the right button will decrease the digit and the generated signal.

When the digit is incremented past 9, or when it is decremented past 0, the digits above the selected adjustment point are rolled up or down, respectively. Using this frequency adjustment scheme, the user can conveniently pick an “increment” digit and manually scan frequencies with the desired granularity. Rough scans can manually be done by positioning the cursor under the 100 kHz digit or the 1 MHz digit, giving a wide and course scan of the frequencies with a quick twist of the dial.

The signal frequency can then be set to the area of interest and the cursor set to a lower granular digit (e.g., 10 kHz or 1 kHz) in order to manually perform a detailed scan while watching displayed results for SWR, impedance and reactance.

MODE

Successively pressing the MODE button you can select one of the MR100 operating modes: impedance (magnitude), complex impedance, capacitance, inductance, and off.

Impedance Mode (magnitude)

This is the main mode of the instrument and measures the SWR and the magnitude of the impedance. An example screen is the following:

SWR 14,10.000

1.02 Z = 40Ω

- The top line indicates the mode and the frequency
- The first number on the second line is the SWR, in this case 1.02:1
- The second number is the impedance magnitude (modulus), in this case 40 Ω

In this mode the instrument can be used as a VFO as it keeps the signal in the selected frequency continuously.

Complex Impedance Mode

In this mode it is measured the SWR and the complex impedance. An example screen is the following:

IMP 14,10.000

1.02 45 + j 50

- The top line indicates the mode and the frequency
- The first number on the second line is the SWR, in this case 1.02:1

- The middle value is the resistance, i.e. the real part of the impedance, in this case 45 Ω
- Then it is shown the reactance sign, '+' for inductive reactance and '-' for capacitive reactance. If it is not shown, i.e. '' it means that it cannot be determined
- Last term is the reactance, in this case it is 50 Ω inductive reactance

This mode can not be used as a VFO because the frequency is continuously dizzling in order to determine the reactance sign.

Capacitance Mode

This mode allows the measurement of the capacitance. An example screen is the following:

CAP 14,10.000

C = 112.4 pF

- The top line indicates the mode and the frequency
- The bottom line indicates the capacitance in pF

Capacity values must be within the measurement range of the instrument. Given that the maximum impedance specification for the analyzer is 2000 Ω , the display will show a numeric value only when the reactance is less than this value. The formula to calculate the capacity is the following:

$$XC = \frac{1}{2 \times \pi \times F \times C}$$

Inductance Mode

This mode allows the measurement of the inductance. An example screen is the following:

IND 14,10.000

L = 7.8 uH

- The top line indicates the mode and the frequency
- The bottom line indicates the inductance in uH

Inductance values must be within the measurement range of the instrument. Given that the maximum impedance specification for the analyzer is 2000 Ω , the display will show a numeric value only when the reactance is less than this value. The formula to calculate the inductance is the following:

$$XL = 2 \times \pi \times F \times L$$

Off Mode

In this mode it is disabled the DDS and the impedance measurements. It is provided a RF level measurement mode where the measured signal level is displayed in the second line of the

display as a bar graph. This will be useful to know if the antenna is receiving a near RF field which can interfere with the measurements.

OFF



BAND

The BAND button allows selecting the working frequency band within the bands available. Pressing this button sequentially selects the next higher band which value is shown in the LCD, and it is changed the frequency. If it is the first time accessing the band, the frequency will be set to the middle value. Otherwise it will be set the previous frequency value, since this is stored when changing the band.

Band	Lower Frequency	Middle Frequency	Upper Frequency
160M	1,000.000	1,800.000	2,000.000
80M	2,000.000	3,700.000	5,000.000
40M	5,000.000	7,100.000	8,000.000
30M	8,000.000	10,100.000	11,000.000
25M	11,000.000	12,000.000	13,000.000
20M	13,000.000	14,100.000	17,000.000
17M	17,000.000	18,100.000	19,000.000
15M	19,000.000	21,000.000	23,000.000
12M	23,000.000	24,900.000	26,000.000
11M	26,000.000	27,000.000	28,000.000
10M	28,000.000	29,000.000	31,000.000
8M	31,000.000	40,000.000	49,000.000
6M	49,000.000	51,000.000	53,000.000

SCAN

Pressing the SCAN pushbutton will automatically sweep the antenna analyzer test signal across the band range previously selected, incrementing from the lower frequency limit to the upper

frequency limit, in steps according the programmed step value. During the scan the SWR is measured and updated on the screen as well as the current frequency value. Each SWR value is compared to previous value in order to determine if a minima, or a “dip”, has occurred at this point in the scan. If so, that data point is stored for later display. Besides the 2:1 points are stored in order to determine the bandwidth. An example screen during the scan is the following (frequency and SWR are updated continuously):

```
SCAN  14,100.200  
1.30
```

Notice that when detected the 2:1 SWR points the buzzer is sounded to alert the user of the event. After the scan process the instrument will show the bandwidth and after pressing any key the instrument will switch to impedance mode with the frequency set to the frequency value corresponding to the minimum SWR point.

```
BW      35.000  
Press any key
```

In the case of not finding a resonance point the unit will display the following error message on the screen.

```
Err No Matching  
Press any key
```

CONFIG

Successively pressing the CONFIG button you can select one of the MR100 configuration modes and extended functions. To select either option you need to press the button VAL and for exit you need pressing the button CAN.

PC Link

The PC Link function lets you control the MR100 from your PC using the USB connection. The PC USB driver provides an emulation of a COM port and the MR100 provides a command interface so you can be control the instrument from a terminal program such as HyperTerminal or any other program designed for this purpose, e.g. PCC-SARK100.

To use this feature you must have installed the USB driver, see Appendix A: and connect the USB cable. The COM port setting is 57600, 8, n, 1, with no hardware flow control. By entering this function the analyzer will send the following text to the terminal and will display the command prompt:

```
SARK SWR Analyzer V05  
>>
```

The available commands are described in Appendix C: These can be typed from the HyperTerminal window and the results will be returned to the terminal. The MR100 will show the last processed command in the bottom line of the LCD.

Step Size

This function allows you to change the value of the frequency step for the SCAN and for the increase/decrease frequency buttons for the impedance measurement modes. Successively pressing the CONFIG button you can select one of the step values. To select either value you need to press the button VAL and for exit you need pressing the button CAN.

The following values are available: 10Hz, 100Hz, 1kHz, 10kHz, and 100kHz.

Suspend Timeout

This feature allows you to program the user idle time for the automatic power-save feature. Successively pressing the CONFIG button you can select one of the idle time values. To select either value you need to press the button VAL and for exit you need pressing the button CAN.

The following values are available: Off (disabled), 30 seconds, 60 seconds, and 90 seconds.

Calibrate

This function allows calibrating the instrument in order to get better accuracy. By entering this function the user is instructed to follow a series of steps which are described in detail in the Appendix B:

Software Load

Don't update software.

4 Uses for an Antenna Analyzer

The MR100 antenna analyzer is a useful tool for the amateur radio station or the homebrewer's workbench. This section will describe the basic uses, as well some advanced techniques for which you can use the analyzer to get intermediate measurements in order to compute the desired result.

4.1 Antenna Measurements

The antenna is simply connected to the analyzer RF output and the analyzer is set to the desired frequency. The instrument measures the SWR, impedance, resistance, and reactance. The SCAN function will be helpful to automatically find the resonance frequency and the bandwidth of the antenna.

4.2 Measure Feed Point Impedance

Connecting the analyzer directly at the antenna terminals or remotely through a halfwavelength of transmission line allows direct measurement of the antenna terminal impedance. This is often useful with vertical antennas.

A matching network can be connected to the antenna and then adjusted for best SWR on the analyzer.

4.3 Measure Ground Losses

With short vertical antennas, measuring the impedance directly at the feedpoint allows estimation of ground loss or loading coil loss. For example a $\frac{1}{4}$ wave vertical will have a resistance of about 36 ohms at resonance. Any higher reading indicates ground loss.

Similarly shorter antennas (when resonated) will have lower resistance values. Reading a good SWR may mean excess loss and measuring the actual impedance allows gauging just how much loss.

4.4 Adjust Antenna Tuners

The analyzer can be used to adjust an antenna tuner for a perfect match without the need to transmit a strong signal from the station rig. The analyzer uses only milliwatts of power lessening the possibility of causing interference, see Figure 3.

4.5 Capacitor Measurement

There are several ways to measure capacitance with the MR100. The simplest is to connect the capacitor across the RF output connector and select Capacitance from the Mode pushbutton menu. You can accurately measure capacitance values as long as the reactance at the measurement frequency is within the impedance measurement specifications of the analyzer (about 10 to 2000 Ω).

Another way to measure capacitance with the MR100 is to measure it in a series resonant circuit. (See Figure 1 and Figure 5). You will need an inductor of known value and a 51 Ω carbon composition or film resistor. It is recommended that a small 5% tolerance choke with an inductance of between 1 and 10 μH be used. Common RF chokes are fine and can be obtained from most full-service mail order component suppliers.

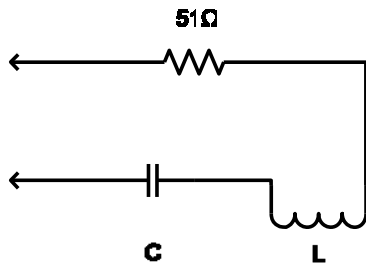

Figure 1

To measure capacitance by the second method, connect the components as shown in Figure 1. Then adjust the operating frequency for lowest SWR and record the frequency. Now you can calculate the capacitance using the formula:

$$C = \frac{25530}{F \times F \times L}$$

Where C is the capacitance in picofarads, F is the frequency in MHz and L is the inductance in microhenries.

4.6 Inductor Measurement

There are several ways to measure inductance with the MR100. The simplest way is to connect the inductor across the RF output connector and select Inductance from the Mode pushbutton menu. You can accurately measure inductor values as long as the reactance at the measurement frequency is within the impedance measurement specifications of the analyzer (about 10 to 2000 Ω).

Another way to measure inductance with the MR100 is to measure it in a series resonant circuit. (See Figure 1 and Figure 5). You will need a capacitor of known value and a 51 Ω carbon composition or film resistor. The capacitor should have a tolerance no wider than 10% and have a low loss dielectric composition such as NP0 ceramic or mica. A capacitance value of about 100 pf is appropriate for many RF measurements.

You can make your own precision capacitor from a piece of coaxial cable. Common RG-58 type 50 ohm coax has a capacitance of about 29 to 30 pf. For example RG58/U is specified at 28.8 pf per foot so a length of about 3.5 ft – including a 1" pigtail for attachment will serve as a fairly accurate 100 pf capacitor.

To measure inductance by the second method, connect the components as shown in as Figure 6. Adjust the operating frequency for lowest SWR and record the frequency. Now you can calculate the capacitance using the formula:

$$L = \frac{25530}{F \times F \times C}$$

Where L is the inductance in microhenries, F is the frequency in MHz and C is the capacitance in picofarads.

4.7 Measure Inductor Q

The Q of an RF inductor can be measured with a very simple setup. First measure the inductive reactance X_L of the inductor and record this value. Now connect it to the Analyzer as shown below in Figure 2.

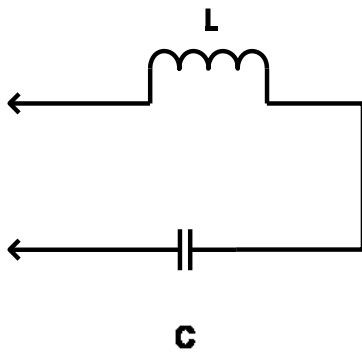

Figure 2

Capacitor C must be chosen to resonate with L at the frequency where you want to measure the inductor's Q. The Inductor and Capacitor Measurement section of this manual shows how this capacitor value can be determined. Now tune the Analyzer for the lowest R (resistance) value with a reading of zero X (reactance). If R is above 10 ohms you can now calculate inductor Q using the formula:

$$Q = \frac{X_L}{R}$$

If R is less than 10 Ω a slightly different method needs to be used. In this case use the test setup shown in Figure 1. Adding the noninductive (carbon composition or film) $\frac{1}{4}$ or $\frac{1}{2}$ watt 51 Ω resistor allows more accurate measurement of the series resistance of the inductor.

Again tune the analyzer for lowest R (resistance) value with a reading of zero X (reactance). Record this resistance value. Now connect the 51 Ω resistor directly across the analyzer's RF output connector and measure its exact value at the resonance frequency and record it. Next subtract the exact 51 Ω resistor value from the measured R value and use this new resistance in the above formula to calculate the Q value.

4.8 Transmission line characteristic impedance

The characteristic impedance of coaxial, twisted pair, open wire or ribbon type feedlines can be estimated using the MR100. Practical measurements are best done in the mid-tuning range of the instrument where accuracy is optimum and feedline lengths are reasonable; so this procedure will be performed between 7 and 21 MHz.

The measurements need to be done with a transmission line over frequencies where the feedline is at about 1/8 wavelength at the low frequency end and something over 1/4 wavelength at the high frequency end, so it is recommended that a length of about 4.9m (16 feet) is used.

Connect the near end of the feedline to the MR100. Connect a 1000 Ω carbon or Cermet potentiometer to the far end with leads no longer than 2.5 cm (one inch) or so. Initially set the pot to its highest value, see Figure 6.

Ensure that the transmission line is supported for its entire length in a fairly straight line and kept several inches from any conductive surface or material. This is important to minimize any detuning effects. Ideally the line should be dressed along to top of a wooden fence or supported by fiber rope or string.

Now tune the MR100 over the range of 7-to-21 MHz while noting the resistive (R) and reactive (X) values. More than likely they will vary widely over the tuning range. Now readjust the potentiometer to a slightly lower value and do another sweep while observing the variation of R and X values. At some potentiometer setting the R value will vary very little over the tuning range while the X value will remain near zero. This is the estimated characteristic resistance.

4.9 Transmission line losses

Transmission line loss for 50-ohm feedlines can be easily measured using the analyzer. The basic operating principle is that loss in transmission lines attenuates RF sent through them. When the line is connected to the analyzer and the far end is short or open-circuited there is a theoretically infinite SWR. If the feedline had zero loss this would be the case. However since any real line has some loss both the forward and reflected power are attenuated and a finite SWR is measured.

For most good quality new coaxial feedlines the loss at HF frequencies will not exceed several dB per 30 meters (hundred feet); however as they age the dielectric becomes lossy so it is a good idea to periodically check the loss. Measurement is simple. All you have to do is to remove the load, short-circuit the far end of the feedline, and then connect the near end to the analyzer's RF output connector. Measure the SWR and refer to table below for the approximate corresponding loss. If the measured SWR is above 9:1 that's good news since the SWR then is less than 1 dB. If you vary the analyzer frequency you will see that SWR decreases with frequency indicating that loss increases at higher frequencies.

Approx Loss	Measured SWR
1 dB	9:1
2 dB	4.5:1
3 dB	3:1
4 dB	2.3:1
5 dB	2:1
6 dB	1.7:1
7 dB	1.6:1
8 dB	1.5:1
9 dB	1.4:1
10 dB	1.3:1

4.10 Transmission line stub lengths

Measurement of quarter and half wave transmission line stubs can be performed regardless of the transmission line characteristic impedance. The method relies on the fact that an open-circuited quarter wavelength line or a short-circuited line acts like a precise short circuit at the chosen frequency of operation.

With either type of feedline first cut it about 10% longer than the desired length, taking the appropriate velocity factor into account. The velocity factor of common feedlines is available from manufacturer's literature or references such as the ARRL Antenna Book. If you cannot find the value or if you are using a custom type of feedline, the "Velocity Factor Measurement" section in this manual provides a way to determine this value. The following formulas can be used to estimate the length of transmission line required.

For a half-wavelength stub the length is:

$$L = \frac{150000 \times VF}{F}$$

Where L is the length in cm, VF is the velocity factor and F is the operating frequency in MHz for the stub.

Similarly for a quarter-wave stub use the formula:

$$L = \frac{7500 \times VF}{F}$$

To determine the length of a half wave stub, connect the near end of the transmission line through a 51 Ω resistor as shown in Figure 4 to the analyzer's RF output connector. Short circuit the two leads at the far end of the half wave stub.

Ensure that the transmission line is supported for its entire length in a fairly straight line and kept several inches from any conductive surface or material. This is important to minimize any detuning effects. Ideally the line should be dressed along to top of a wooden fence or supported by fiber rope or string.

Now tune the MR100 for minimum SWR and note the frequency. This is the frequency where the transmission line is exactly a half wavelength long. If the initial length was chosen properly it should be below the desired frequency. If so, cut off a short length making sure the far end is still short-circuited, and repeat until resonance is achieved at the desired frequency.

For a quarter wave stub, the above procedure can be used except, of course that the length is different and that the far end needs to be open-circuited.

4.11 Transmission line velocity factor

Velocity factor of a transmission line can be measured using techniques similar to the ones used for measuring quarter and half wave stubs. The procedure can be performed at any frequency that the MR100 tunes but it is most practical in the vicinity of 10 MHz where line lengths are reasonable and instrument accuracy is optimum.

Either a quarter wave or half wave length can be used; but using the shorter length consumes less feedline if it will be discarded after the measurement. Begin by cutting a quarter wavelength of feedline using the formula:

$$L = \frac{7500 \times VF}{F}$$

For a frequency of 10 MHz and assuming a VF (Velocity Factor) of 1.

Now connect the near end of the feedline to a 51 Ω resistor as shown in Figure 7 then to the analyzer's RF output connector. The far end must be open circuited. Ensure that the transmission line is supported for its entire length in a fairly straight line and kept several inches from any conductive surface or material. This is important to minimize any detuning effects. Ideally the line should be dressed along to top of a wooden fence or supported by fiber rope or string.

Now tune the MR100 for lowest SWR and note the frequency. VF can now be calculated using the formula:

$$VF = \frac{10}{F}$$

Where F is the measured frequency in MHz.

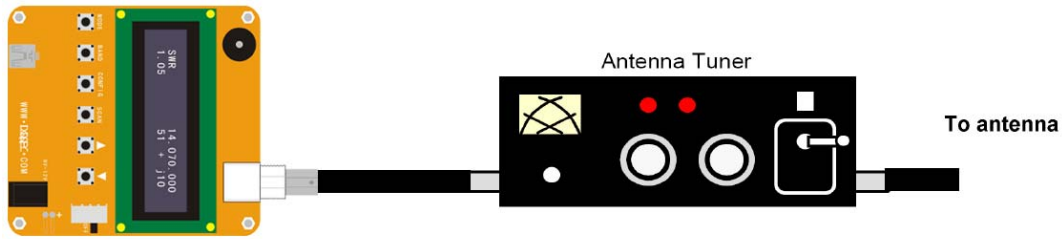

Use the SWR mode to deal in the desired operating frequency.
Then adjust the tuner, disconnect the MR100, connect the Xcvr, and operate!

Figure 3, Adjust antenna tuners

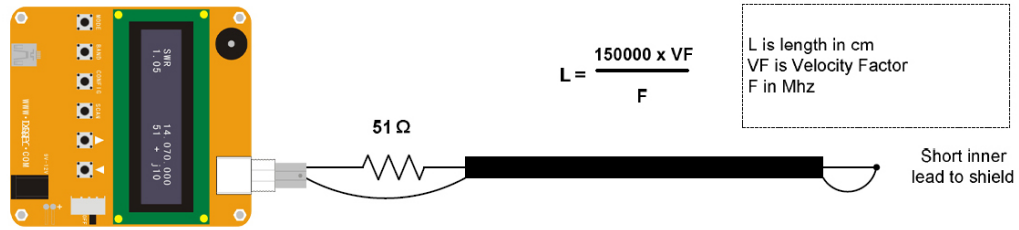

Tune for minimum SWR
Freq where SWR is min is 1/2 wavelength

Figure 4, Adjust antenna tuners

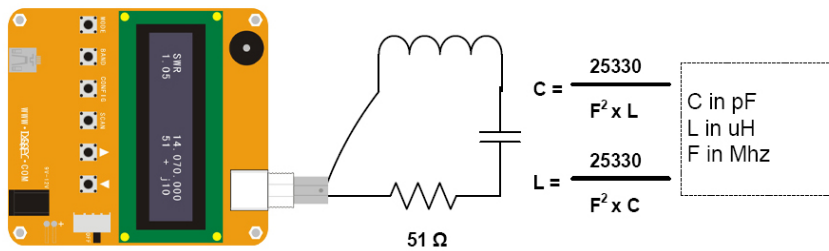

Adjust freq "F" for lowest SWR

Figure 5, Capacitor or inductor measurement

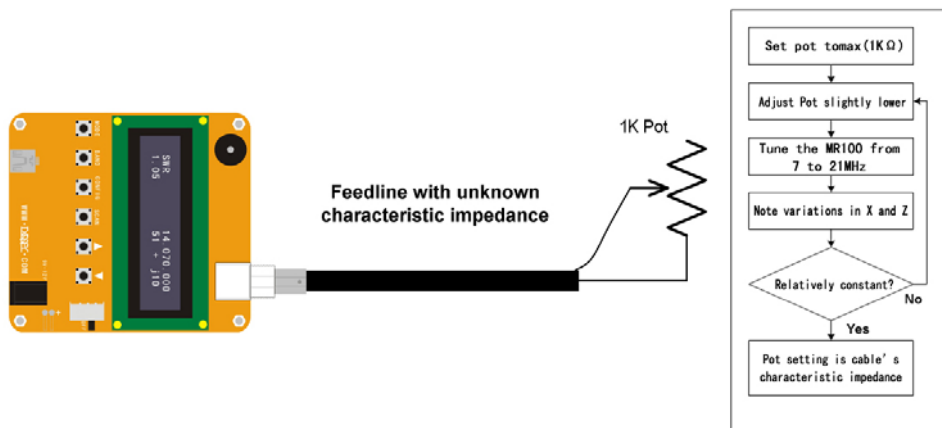

Figure 6, Determining feedline characteristic impedance

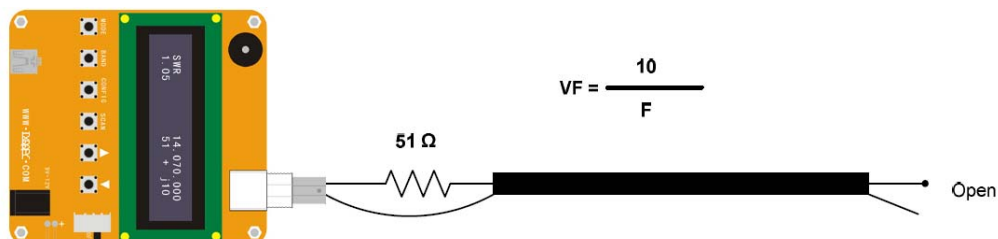

Figure 7, Determining feedline velocity factor

5 PC Software

The MR100 is controllable from the PC and allows the collection of measurements to be processed by an analysis program. In the project website you can find a simple command line program, PCC-SARK100, which performs control and data capture from the MR100 and generates a data file compatible with Excel macro ZPlots from Dan Maguire AC6LA. This macro performs the analysis of the measures and displays them in different graphs.



Double click download: PCC-SARK100.zip

The PCC-SARK100 is a simple command line program which scans in the selected frequency range and stores the measurement results in a file format supported by ZPlots.

Usage:

➤ PCC-SARK100 -c<com port> -s<start freq> -e<end freq> -t<step value> -o<output file>

Where:

- -c<com port name> COM port name
- -s<start freq> Start frequency in Hertz
- -e<end freq> End frequency in Hertz
- -t<step> Step value in Hertz
- -o<output file> Output file name (without path)

Example:

» PCC-SARK100 -cCOM5 -s14000000 -e16000000 -t10000 -oDipole20m.csv

ZPlots

ZPlots is an Excel macro developed by Dan Maguire AC6LA, which provides the data analysis and display graphs of the impedance data captured by the MR100 antenna. Usage is very simple, you select the file captured by PCC-SARK100 and automatically displays a representation of the actions of the antenna to the SWR, resistance, reactance, etc.. It also represents Smith chart format. In the following pages there are examples of ZPlots graphs.

The complete manual of the original program is available on the project website.

Appendix A: USB Driver Installation

The MR100 incorporates a USB interface for PC connection. This interface is implemented by the FTDI Chip FT232R chip which requires prior installation of a driver "Virtual COM Port (VCP) available at the following link:

<http://www.ftdichip.com/Drivers/VCP.htm>

This driver is available for multiple operating systems on which you access the manufacturer's website and select the appropriate driver, always bearing in mind that the chip is the FT232R. Preferably you install by using the "setup executable" and following the manufacturer's instructions.

Once installed and connected the MR100 you can verify proper installation by entering in the Device Manager of the Windows Control Panel. By connecting the MR100 you should see a new COM port with the FTDI driver reference. Please note the COM port name as it will be necessary to know to use the MR100 from your PC, eg for software updates or to control the instrument from HyperTerminal.

Appendix B: Calibrating the Analyzer

To improve the accuracy of the analyzer this should be calibrated. This is a simple procedure that just requires loads of known value and follows the outlined procedures. The calibration data is stored in nonvolatile memory and will remain stored during the life of the instrument. Recalibration will be necessary in the case of a software update because the stored calibration data are lost during the loading process.

It is essential to properly implementing the loads by integrating in BNC connectors and minimizing the length of the connections. Another method is to use a BNC to RCA adapter and mount the resistors in RCA connectors, as they are cheap and easy mounting of resistors, as shown in the following illustration:



The instrument normalizes the gains of the four legs of the bridge for the different bands of operation, creating the correction values to be stored in nonvolatile memory. These correction values are calculated for different load conditions during the calibration process and are subsequently used for measures to compensate for gain differences of the legs of the bridge.

Calibration Procedure

1. Select the "Calibrate" on the setup menu
2. The instrument will prompt the user with the LCD text "Disconnect Load", indicating to remove any load from the RF connector. Press the button VAL after disconnecting the load and then the display will show "In Progress..." indication that calibration is in progress
3. Then it will prompt to connect a 50 Ω load "Conn 50 Ω Load". Plug the 50 Ω load and then press VAL. The display will show "In Progress..." indication that calibration is in progress
4. After that it will prompt to connect a 150 Ω load "Conn 150 Ω Load". Plug the 150 Ω load and then press VAL. The display will show "In Progress..." indication that calibration is in progress

5. Subsequently it will prompt to connect a 274 Ω load "Conn 274 Ω Load". Plug the 274 Ω load and then press VAL. The display will show "In Progress..." indication that calibration is in progress
6. Once the calibration is finished it will show the text "Done". This means that the calibration process has been completed and stored in the EEPROM. Just press VAL to continue

Appendix C: Making a Dummy Antenna for Testing

It may be desirable to have a dummy antenna for testing the MR100. A dummy antenna is simply a three-component circuit that is resonant at a specific frequency and has a purely resistive characteristic at the resonance frequency. The dummy antenna can be used in place of a real antenna during initial testing of the instrument.

The dummy antenna consists of one resistor, one inductor and a capacitor in a series circuit, built at the end of a BNC connector that can be connected to the MR100 antenna. The table below shows the component values for dummy antennas to any of the specified frequencies:

Freq (Mhz)	C (pF)	L (uH)	Core	#Turns
7.1	82	6.8	T50-2	37
10.1	47	5.28	T50-2	33
14.1	27	4.7	T50-2	31
18.1	22	3.51	T37-2	30
21.2	27	2.08	T37-2	23
28.5	15	2.08	T37-2	23

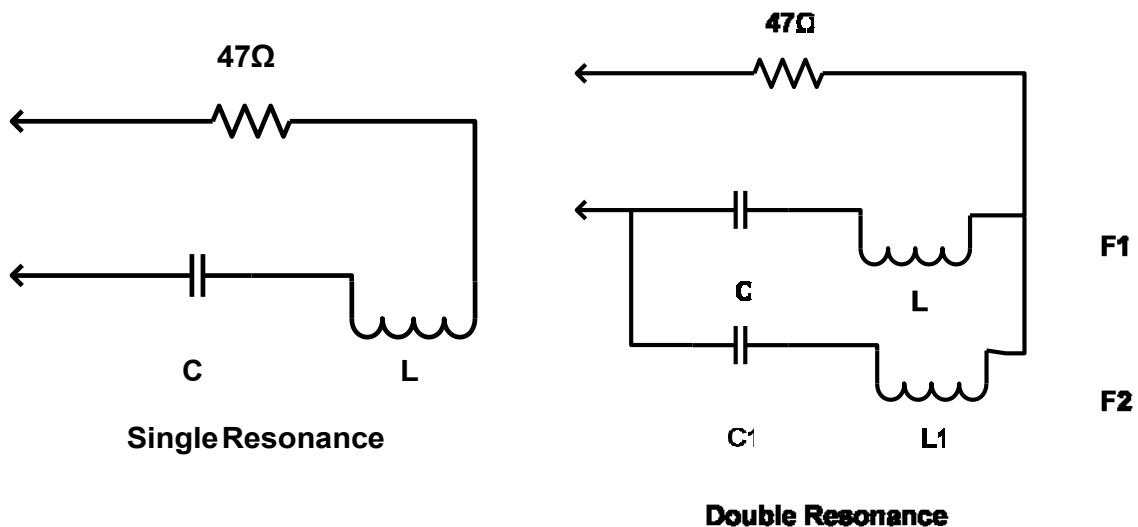

Appendix D: PC Command Interface

Command	On
Description	Enables DDS signal generation. Requires setting correct DDS frequency
Arguments	--
Response	OK
Error response	Error: freq not set
Example	>>on OK

Command	off
Description	Disables DDS signal generation
Arguments	--
Response	OK
Error response	--
Example	>>off OK

Command	freq
Description	Sets DDS frequency
Arguments	{frequency} Frequency in Hertz
Response	OK
Error response	Error: invalid freq
Example	>>freq 14070000 OK

Command	imp
Description	Get impedance values
Arguments	--
Response	{SWR},{R},{X},{Z}
Error response	--
Example	>>imp 1.05,52,10,51

Command	raw
Description	Get raw bridge voltages
Arguments	--
Response	{Vf},{Vr},{Vz},{Va}
Error response	--
Example	>>raw 257300,165500,31800,214500

Command	scan
Description	Scans from specified start to end frequency and get impedance values
Arguments	{freq_start} Start freq. in Hz {freq_end} End freq. in Hz {step} Step in Hz
Response	Start {SWR},{R},{X},{Z} {SWR},{R},{X},{Z} ... End
Error response	<ul style="list-style-type: none"> • Error: expected freq val • Error: expected step val
Example	>>scan Start 1.05,52,10,51 1.05,52,10,51 .. End

Command	Scanr
Description	Scans from specified start to end frequency and get raw bridge voltages
Arguments	{freq_start} Start freq. in Hz {freq_end} End freq. in Hz {step} Step in Hz
Response	Start {Vf},{Vr},{Vz},{Va} {Vf},{Vr},{Vz},{Va} ... End
Error response	<ul style="list-style-type: none"> • Error: expected freq val • Error: expected step val
Example	>>scan Start 257300,165500,31800,214500 257300,165500,31800,214500 ... End

Appendix E: Quick Reference Sheet

